

Improved Pro Series® Cylinders

CYLINDER AND KEY ENHANCEMENTS

In August 2001, Master Lock made enhancements to our W6000 and W7000 cylinders used in the Pro Series™ padlocks. The tighter manufacturing tolerances expand the number of key codes available while at the same time reducing the risk of inadvertent key interchange.

The keys affected are the 6000 and 7000. Rounded bottom keys stamped 6000B and 7000B have replaced them.

New “B” keys and old keys can be used in the exact same padlock. Just be sure to use care when duplicating the key. If you do not have the exact same blank as the key you are duplicating, you must cut by code to avoid the new cut key from being off by .0125" and unusable.

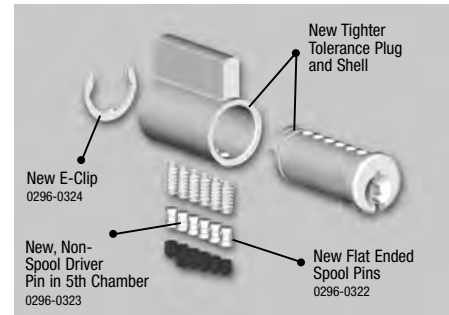
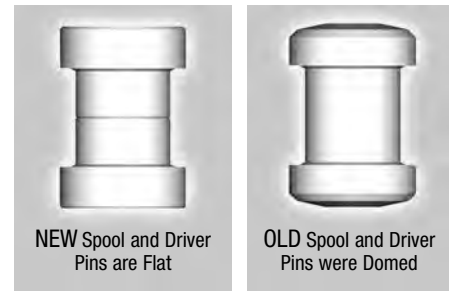

NEW KEYS ROUND ON THE BOTTOM

Avoid duplicating an old style key onto a new “B” style round-back blank. Cuts will be .0125" too deep. Use codes below to cut.

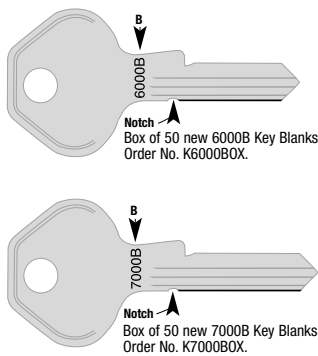

OLD KEYS FLAT ON THE BOTTOM

Avoid duplicating a “B” round-back key onto an old style blank. Cuts will be .0125" too shallow. Use codes below to cut.

Original blanks no longer available.

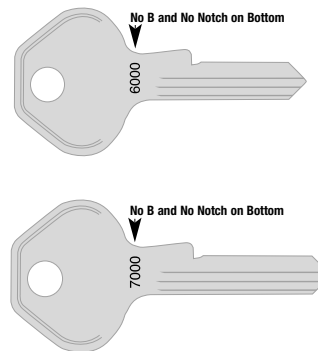

Cut	Root Depth
0	.2845"
1	.2690"
2	.2535"
3	.2380"
4	.2225"
5	.2070"
6	.1915"
7	.1760"



Cut	Root Depth
0	.271"
1	.256"
2	.240"
3	.225"
4	.209"
5	.194"
6	.178"
7	.163"

