

Model No. T0-331ML  
XX-Large Reinforced Security Digital Safe

**Best Used For:**



A4 Paper Documents



Jewels



Laptop Computers



Small Electronics



Storage Devices,  
USB Flash Drives

## Overview & Features

## Product Features

- Solid steel construction
- 4 steel live-locking bolts and concealed hinge for more protection against attacks and prying attempts
- Programmable Digital Combination with override key - includes 2 keys
- Carpeted floor
- 3 adjustable shelves - Key rack, Bungee organizational system
- Bolt down hardware included

## Product Details

The Master Lock XX-Large Digital Combination Safe Reinforced Security is designed to protect your valuables against thefts and other attacks. The solid steel construction, steel live-locking 1-inch (2.5 cm) bolts and concealed hinge door give assurance to the safety of your irreplaceable items. The programmable electronic lock allows you to choose your combination while the override key makes sure you can always access to your safe, even in the case of forgotten combination. Equipped with adjustable shelves, it offers you a big storage capacity and its carpeted floor keeps the content protected from scratching during storage.

# Product Specifications

<b>Product Number</b>	T0-331ML
<b>Exterior dimensions (H x W x D)</b>	95cm x 55,1cm x 50,2cm
<b>Interior dimensions (H x W x D)</b>	90,9cm x 52cm x 35,9cm
<b>Interior Volume</b>	169,7L
<b>Weight W/o Packaging</b>	99,8kg
<b>Colour</b>	Black
<b>Batteries</b>	Requires 4 AA alkaline batteries (not included)
<b>Description</b>	Retail Boxed Packaging
<b>Master Carton Qty</b>	1

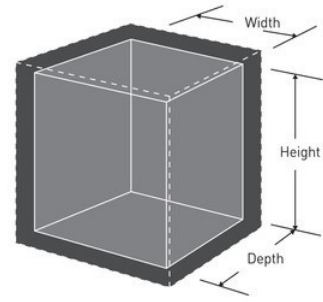

---

## Master Lock Europe S.A.S.

10 avenue de l'arche - Le Colisée Gardens, bâtiment A - 92 400 Courbevoie - La Défense - France  
O:+33-1-41437200 | F:+33-1-41437204  
[www.masterlock.eu](http://www.masterlock.eu)