

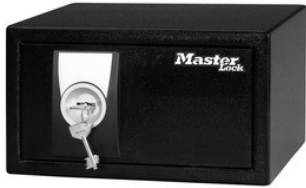

Model No. X031ML

Small keyed safe



Best Used For:



Cheque Books



Passports



Small Electronics

Overview & Features

Product Features

- Solid steel construction
- 2 steel live-locking bolts and concealed hinge for more protection against attacks and prying attempts
- 6 lever key lock - includes 2 keys
- Carpeted floor
- Bolt down hardware included

Product Details

The Master Lock No. X031ML Small Keyed Safe is ideal for protecting small but precious valuables. The high security key helps keep your valuables safe from unauthorized access, while the carpeted floor keeps the content protected from scratching during storage.

Product Specifications

Product Number	X031ML
Exterior dimensions (H x W x D)	16,7cm x 29cm x 26,4cm
Interior dimensions (H x W x D)	16,3cm x 28,6cm x 21,3cm
Interior Volume	9,93L
Weight W/o Packaging	4,4kg
Colour	Black/Grey
Description	Retail Boxed Packaging
Master Carton Qty	1

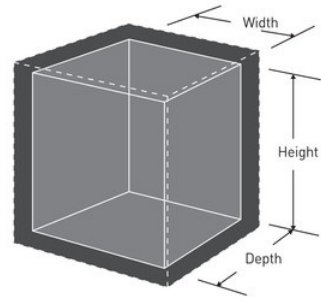

Master Lock Europe S.A.S.

10 avenue de l'arche - Le Colisée Gardens, bâtiment A - 92 400 Courbevoie - La Défense - France
O:+33-1-41437200 | F:+33-1-41437204
www.masterlock.eu